

D-RING HAND PLIERS RINGER9/16



WARNINGS

- **Always** read tool manual before operating.
- Always wear safety glasses while operating or while in the vicinity of a tool in operation.
- For testing, always cycle tool away from work to insure proper ring closure. For safety reasons, an improperly functioning tool **must not** be used.

OPERATION

▲WARNING:

Always handle tool with care:

- Never engage in horseplay.
- Keep others at a safe distance from the tool while the tool is in operation as actuation occurs, possibly causing injury. Keep hands and body away from the jaw mechanism of the tool.
- Never place a hand or any part of body in jaw mechanism area of tool.

SAFETY INSTRUCTIONS



WARNING:

The employer and/or user must ensure that proper eye protection is worn. Eye protection equipment must conform to the requirements of the American National Standard Institute, ANSI Z87.1-1979 and provide frontal and side protection. Eye protection should be worn by the operator and others in the work area when loading, operating, or servicing this tool. Eye protection is required to guard against possible flying particles and/or debris, which could cause severe eye injury.

NOTE: Non-side shielded prescription glasses and faceshields alone do not provide adequate protection.

STANLEY Fastening Systems®

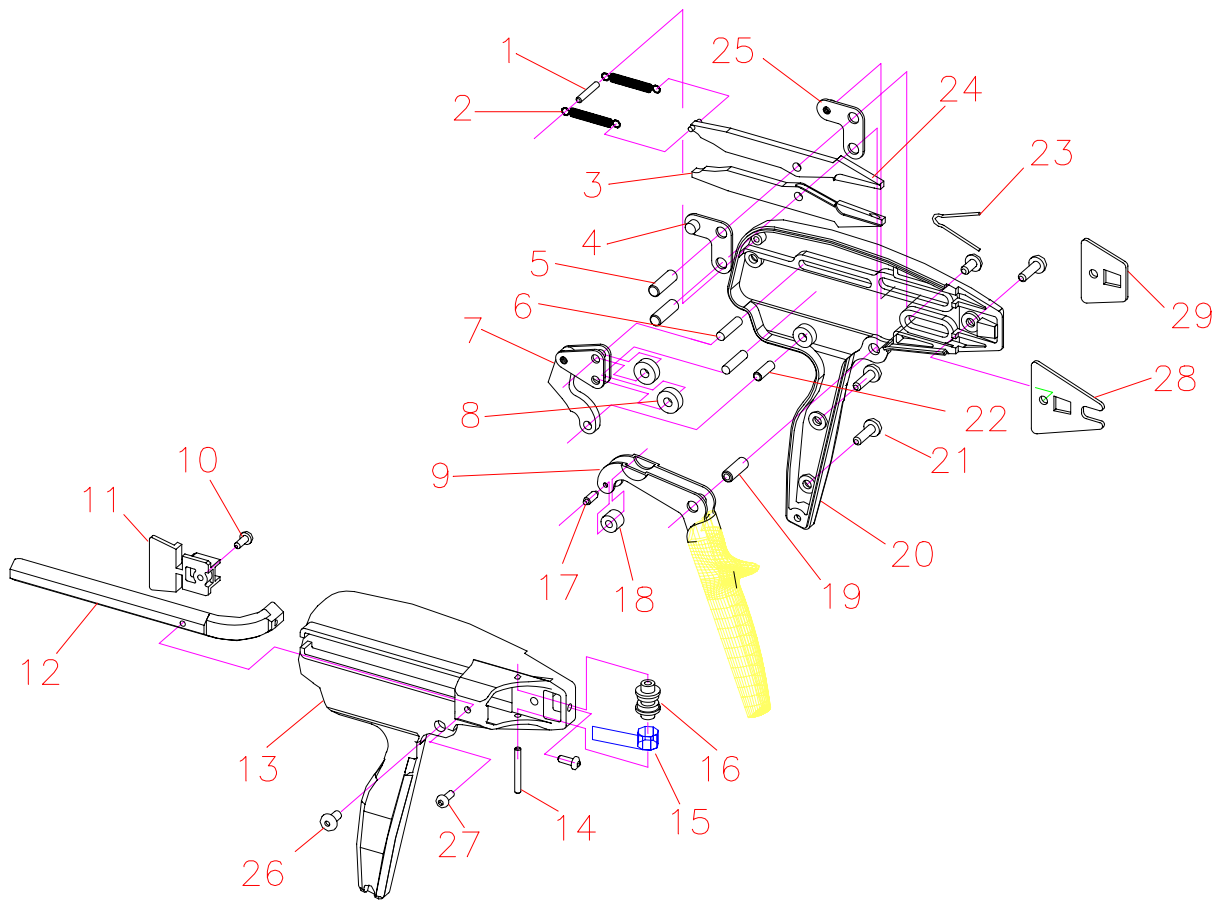

PARTS LIST			
ITEM	DESCRIPTION	PART NUMBER	QTY.
1	PIN, .123 X .73	B03828-073	1
2	SPRING, JAW RETURN	SC95	2
3	JAW, LOWER	C03782F	1
4	ASS'Y, R. JAW LINK/RIVET	AB03808	1
5	PIN, .248 X .73	B03830-073	2
6	PIN, .185 X .73	B03829-073	2
7	ASSEMBLY, DELTA / LAMINATION	AB03809	1
8	ROLLER, JAW	B03801	2
9	HANDLE, POWER	C03777	1
10	SCREW, #6-19 X .25 PLASTITE PAN HD. TORX	TL846206	1
11	PUSHER, RING	B03779	1
12	MAGAZINE, RING	B03778	1
13	HOUSING, RIGHT	D03775F	1
14	PIN, .125 X .1.00	B03828-100	1
15	SPRING, PUSHER	SC96	1
16	ROLLER, PUSHER SPRING	B03780	1
17	RIVET, POWER / LINK	B03806	1
18	ROLLER, HANDLE	B03804	1
19	PIN, RINGER PIVOT	B03987	1
20	HOUSING, LEFT	D03776	1
21	SCREW, #8-16 X .625 PLASTITE PAN HD. TORX	TL848210	4
22	PIN, .185 X .54	B03829-054	1
23	SPRING, JAW OPEN	B03802	1
24	JAW, UPPER	C03781F	1
25	ASS'Y, L. JAW LINK / RIVET	AB03807	1
26	SCREW, BUTTON HEAD CAP #8-32 X .375	TL778206	2
27	SCREW, #6-19 X .375 PLASTITE PAN HD. TORX	TL846208	2
28	GUIDE, RINGER	B04102	1
29	INSERT, RINGER NOSE (OPTIONAL)	B04103	1

RECOMMENDED SPARE PARTS LIST					
ITEM	DESCRIPTION	PART NUMBER	NO. OF TOOLS		
			1	5	10
2	SPRING, JAW RETURN	SC95	2	2	4
11	PUSHER / SPRING ASSEMBLY	AB03810	1	1	4
12	MAGAZINE, RING	B03778	1	1	2
23	SPRING, JAW OPEN	B03802	2	2	4

ASSEMBLIES			
(THE FOLLOWING WILL BE SOLD ONLY AS ASSEMBLIES)			
ITEM	DESCRIPTION	PART NUMBER	ITEM NUMBERS
11	PUSHER / SPRING ASSEMBLY	AB03810	10, 11, 15, 16

RECOMMENDED TOOL LIST	
QTY.	DESCRIPTION
2	3/32 HEX KEY ALLEN WRENCH
1	T15 TORX DRIVER
1	T20 TORX DRIVER
1	3/32 PIN PUNCH

TO DISASSEMBLE

1. Remove remaining rings.
2. Remove (1) #8-32 button head screw (#26) from pivot pin (#19) (use two 3/32 hex Allen wrenches).
3. Remove pivot pin with remaining #8-32 button head screw.
4. Lay tool magazine side down on a clean flat surface.
5. Remove (4) #8-16 torx head screws (#21).
6. While holding tool together, turn the tool over to flat side of housing.
7. While holding power handle (#9) down, remove magazine side of housing. All internal parts are now exposed.
8. Remove (2) #6-19 torx head screws (#27) from magazine (#12) and housing (#13).
9. Remove magazine by rotating bottom of magazine toward handle of housing and sliding forward.
10. Using a 3/32 punch, carefully drive pin (#14) from housing (#13). Pusher assembly may now be removed.

TO RE-ASSEMBLE

1. Place left housing half (#20) onto a clean flat surface.
2. Insert Ringer guide (#28) into the front of the housing. Optional: Install nose insert (#29) into the front of the housing if the Ringer guide is not preferred.
3. Install left jaw link (#25) guide pin into left housing (#20) groove.
4. Install upper jaw (#24) over link and insert pin (#5).
5. Install lower jaw (#3) onto left link aligning holes.
6. Install jaw open spring (#23) between jaws in grooves orientated with open end to the front of the tool.
7. Install right link (#4) over jaws and previously installed pin (#5) and insert second pin (#5).
8. Hook one end of spring (#2) onto bottom rear post of upper jaw (#24). Insert pin (#1) through opposite end of spring. Using the pin to extend the spring, install end of pin into back hole of housing (#20).
9. Hook remaining spring (#2) onto top rear post of upper jaw and extend over pin (#1).
10. Assemble rollers, delta/lamination assembly and pins (#6, #7 and #8). Use grease during assembly to hold parts together as well as for proper tool function.
11. Place delta/lamination assembly with rollers and pins (#6, #7 and #8) into housing (#20) inserting pin (#6) into slot behind upper jaw (#24).
12. Install roller (#18) onto rivet (#17).
13. Assemble movable power handle sub-assembly (items #9, #17 and #18). Gently spread arms of movable power handle (#9) and insert rivet with roller into the cross holes in the handle, lightly grease roller.
14. Gently lifting lower linkage of delta/lamination assembly, slide linkage through arms of movable power handle.
15. Insert pin (#22) through linkage (#7) into housing (#20).
16. Assemble (1) #8-32 button head screw (#26) onto pivot pin (#19).
17. Insert pivot pin (#19) into left housing (#20) and power handle (#9) from the bottom side.
18. Slide pusher / spring assembly (#11) through the tunnel of housing (#13) from back to front. Pull spring / roller forward until it aligns with hole in housing. Carefully drive in pin (#14), through housing and spring roller.
19. Slide magazine (#12) through housing from front to the back rotating as needed. Attach with (2) #6-19 torx head screws (#27).

20. Place right housing half (#13) over left housing (#20) being careful to align all pins with holes and slots. (Hint: align pin #1 first.)
21. Install (1) #8-32 button head cap screw (#26) into pivot pin (#19).
22. Carefully turn over tool onto flat surface. Re-assemble tool with (4) #8-16 torx head screws (#21).

LUBRICATION

1. The D-Ring Hand Pliers are designed with all metal parts produced from stainless steel to insure long, trouble-free service with minimal lubrication.
2. Excess oil in the pliers will attract dirt, lint, and the adhesive material used in collating the fasteners, preventing smooth operation. When lubrication is used, always use a good water dispersing lubricating oil into the tool. (i.e. WD-40). Disassembly is not required to apply spray lubricant.
3. When servicing or repairing tool use **white lithium grease** on all moving parts.

TIPS ON EXTENDING TOOL LIFE

The serviceable life of the D-Ring Hand Pliers can be extended greatly by using the following guidelines:

1. Always use Stanley Fastening Systems brand fasteners. **Never** replace worn or broken parts with anything other than genuine Stanley Fastening System parts. **Generic fasteners** may shorten the life of your hand pliers and **will void** the manufacturer's warranty.
2. Keep your pliers clean and dry.
3. Exercise caution not to drop equipment. Pliers dropping onto the floor or ground is a primary reason for parts replacement.
4. Under normal use occasionally spray a water dispersing lubricating oil into the tool.

HELPFUL HINTS FOR FIELD SERVICE TOOL JAMS

1. The most common reason for jamming problems in the hand pliers is insufficient pusher spring tension. This occurs when the tool is forced to function when ring quantity is not sufficient. This tool is not designed to empty its magazine during operation. Reload when the pusher makes contact with the tunnel in the housing.
2. If a jam occurs, pull pusher back to the locked position and pull rings out of jaw mechanism area. Point nose of tool down while holding onto rings, cycle tool slowly. Operator may need to shake pliers to assist the ring(s) in falling out. This should force jammed ring(s) out of jaw mechanism.
3. If procedure "2" does not clear the tool, lay tool on a clean flat surface with magazine side up. Remove jammed rings from between the jaws with a small screw driver. Remove build up of dirt, lint, and any other foreign debris and check for worn or damaged parts.
4. If jamming still occurs, disassemble and inspect pliers for worn or damaged parts.
5. Replace worn or damaged parts to keep tool operating properly.

SPECIFICATIONS AND TYPES OF MATERIALS AVAILABLE BY PART NUMBER

Part Number	Per Strip #	Per Box #	Material	Wire Diameter	Ring I.D.	Ring Leg Opening	Operating Rang of Tool RINGER9/16
RINGR15G50	50	2,500	Galvanized	0.070	0.56	0.38	3/16
RINGR15SS50	50	2,500	Stainless Steel	0.070	0.56	0.38	3/16
RINGR15G50B	50	2,500	Galvanized	0.070	0.56	0.38	3/16
RINGR15SS50B	50	2,500	Stainless Steel	0.070	0.56	0.38	3/16

* “B” Indicates a Blunt pointed ring, no letter following part number indicates a Sharp pointed ring.

IMPORTANT HELPFUL HINTS IN OPERATING TOOL

1. Take care when pulling the pusher back. If pulled too far or too hard, the pusher can be pulled out of the guide channel.
2. If the tape on the collated rings tails, the operator must not try to remove the extra tape. The pulling action to remove tape will cause the next ring to jam.
3. The power handle should be released as rapidly as possible. Operating the tool this way will allow the tool to function at its optimum performance. When handle is released slowly the jaws may not return to home position and jamming may occur.
4. Do **not** force the actuation of the tool when jammed, this may cause damage to the tool.

RING DOES NOT CLOSE COMPLETELY

1. Check for foreign debris in the jaw area. This is especially true in the area between the housing and rollers.
2. The jaws may be worn from extended use, replacing the jaw(s) is recommended.
3. When the tool is used in corrosive applications, a water dispersing lubricating oil should be applied on a regular basis to the jaw pins and rollers. Unlubricated and/or corroded jaw pins may cause the tool to function poorly.

FEEDING PROBLEMS

1. If rings do not feed smoothly down the magazine, check pusher spring for tension. If the magazine is covered with dirt from field use, clean the magazine and apply a light coating of water dispersing lubricating oil. If magazine is worn or damaged, replace it.
2. When rings feed properly on the magazine but do not feed into the jaws without spitting out of the magazine side of the tool, or if the rings sit in the jaw grooves on an angle, check jaws to insure freedom of movement.
3. If jaws do not open completely allowing the next ring to enter jaws, check the jaw open spring for wear or need of replacement.
4. If jaws do not return to the fully retracted position,, check the condition of the jaw return springs.
5. **NEVER USE LOOSE RINGS IN THE RINGER9/16.**
6. Use only Stanley Fastening Systems rings designed specifically for the Ringer9/16.

LIMITED WARRANTY

Stanley Fastening System warrants to the original retail purchaser that this product is free from defects in material and workmanship, and agrees to repair or replace, at Stanley Fastening’s option, any defective product within 60 days from the date of purchase. This warranty is not transferable. It only covers damage resulting from defects in material or workmanship, and it does not cover conditions or malfunctions resulting from normal wear, neglect, abuse, or accident.

THIS WARRANTY IS IN LIEU OF ALL OTHER EXPRESS WARRANTIES. ANY WARRANTY OF MERCHANTABILITY OR FITNESS FOR A PARTICULAR PURPOSE IS LIMITED TO THE DURATION OF THIS WARRANTY. STANLEY FASTENING SYSTEMS SHALL NOT BE LIABLE FOR ANY INCIDENTAL OR CONSEQUENTIAL DAMAGES.

Some states do not allow limitations on how long an implied warranty lasts, or the exclusion or limitation of incidental or consequential damages, so the above limitations or exclusions may not apply to you. This warranty gives you specific legal rights, and you may also have other rights which vary from state to state.

To obtain warranty service, you must return the product at your expense together with the proof of purchase to the Stanley Fastening warranty repair center in Shelbyville, Indiana or you may call us at (317)398-0761.

