



Great Lakes Fastening
2810 Hoitt Ave.
Knoxville, TN 37917
Phone: 877-969-0031
Fax: 877-969-0032



GLF315

OPERATING INSTRUCTIONS & PARTS LIST

For best operating results and long life, maintain the tool in good working order, do not drop the tool, keep the mechanism free from dirt and other foreign matter and do not operate the tool at air pressures above 100 P.S.I. (7.03 kg/cm²). Although your clip ring tool is of high quality and made to exacting standards, failure to follow proper operational precautions may result in damage to your tool and shorten its useful life.

OPERATION

The air powered clip ring tool should be held firmly in the hand and in most operations the tool is used 90 degrees to the work performed. It should be kept in mind that in using the air powered clip ring tool, this is like any other tool and should be properly maintained. One area of maintenance to be conscious of is when pushing the tool into foam, it should be cleaned occasionally. Also, when "grabbing" a group of wire, the tool is frequently used as a pusher puller and/or a variety of other things. The most important point to remember is to take a long, hard look at your work and choose the best way in which to do it. Obviously, the less the tool is abused, the better. The tool should be handled firmly in your hand and don't stretch too far

when you use it in the direction of your application. Please also note that the tool should make a complete closure of the fastener. If for any reason you are not getting complete closure, check to make sure that the application is correct and that the tool is cycling completely.

Obviously, moisture, dirt or any other foreign matter that is inside the tool will reduce its Operational efficiency. Please take care in handling, operation and maintenance of your tool for a long and useful work life.

AIR PRESSURE

Air pressure should be maintained at 85 - 96 P.S.I (5.98-6.68 kg/cm²) using 1/4" (6.35mm) ID air hose. Higher pressures will not increase the operating speed of the tool and may cause damage to it.

AIR FILTER AND REGULATOR

The air line should have an attached air line filter and regulator sufficient to provide a constant and even flow of clean, dry air. The filter should be installed as close as possible to the tool. Dirt or moisture in the air line will adversely affect the smooth operation of the tool and decrease its serviceable life.

LUBRICATION

To insure long, trouble-free service, we recommend Air Line Lubricators and Filter Units for proper lubrication and clean, dry air. A good grade of oil that emulsifies in water is recommended for air tools.

MANUAL OILING

Although the jaws and other moving parts of the tool do need to be oiled, periodic oiling in small amounts may increase the serviceable life of the tool that receives heavy use.

HOG RINGS

These rings are available from GLFast and will be shipped promptly from stock. PLEASE SEE HOG RING STYLES CHART for further details regarding materials, points and size of HOG RING.

REPAIR AND SERVICE PARTS

If the tool is not operating properly, remove it from service at once and have it checked for proper operation. GLFast will ship replacement parts for repairs. Parts price lists are available upon request. Use only parts that are specifically fabricated for the tool which you own.

WARNINGS

- Do not point the tool at any person. Keep hands and clothing away from the front of Jaws of the tool and away from all moving parts. Injury may result. Failure to follow these precautions may result in serious injury.
 - Always read tool manual before operating.
 - Always wear safety glasses while operating or while in the vicinity of a tool in operation.
 - For testing, always cycle tool away from work to insure proper ring closure. For safety reasons, an improperly functioning tool must not be used. When operating tool, never point or actuate tool other than into work.
 - Operate tool in an unobstructed work area.
 - Disconnect air supply prior to maintenance or repair of tool.
 - Use clean dry air to maximize efficiency. Do not Exceed 100 P.S.I. (7.0 kg/cm²)
 - Do not use bottled gases such as hydrogen, carbon dioxide, oxygen, etc.
 - Tools shall be operated with a fitting or hose coupling on/ or near the tool in such a manner that all compressed air in the tool is discharged at the time the fitting or hose coupling is disconnected.
- OPERATION
- Always handle tool with care:
 - Never engage in horseplay.
 - Never pull the trigger unless nose of tool is directed toward the work.
 - Keep others at a safe distance from the tool while the tool is in operation as actuation occurs, possibly causing injury. Keep hands and body away from the jaw mechanism of the tool.
- LOADING TOOL
- When loading tool :
- Never place a hand or any part of body in jaw mechanism area of tool.
 - Never point tool at anyone.
 - Never actuate tool when loading, accidental injury may occur.

GLF315

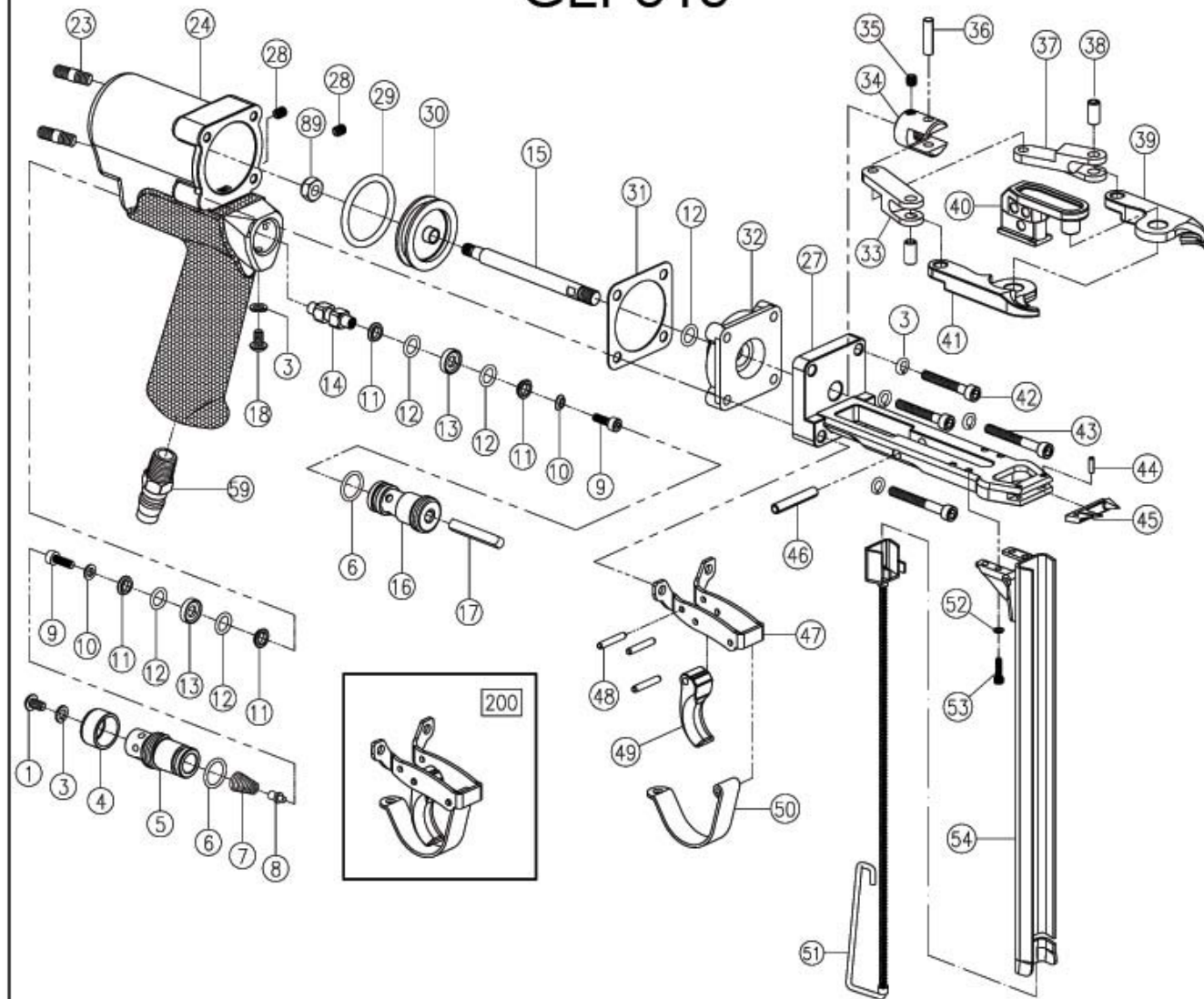

ITEM	DESCRIPTION	PART NUMBER	QTY
1	Set Screw	AD01001	1
3	Shakeproof lock Washer	AD01003	6
4	Air Deflector	AD01004	1
5	Rear Valve Seat	AD01005	1
6	O-Ring	AD01006	1
7	Throttle Spring	AD01007	1
8	Throttle Spring Locator	AD01008	1
9	Throttle Valve Screw	AD01009	2
10	Valve Screw Washer	AD01010	2
11	O-Ring Support	AD01011	4
12	O-Ring	AD01012	5
13	O-Ring Center Support	AD01013	2
14	Throttle Valve Spacer	AD01014	1
15	Piston Rod	AD01015	1
16	Front Valve Seat	AD01016	1
17	Throttle Stem	AD01017	1
18	Button Head Cap Screw	AD01018	1
23	Stud	AD01023	2
24	Cylinder Housing Assembly	AD02024	1
27	Carriage Assembly	AD01027	1
28	Set Screw	AD01028	2
29	O-Ring	AD01029	1
30	Piston	AD01030	1
31	Cylinder Gasket	AD01031	1
32	Piston Stop Spacer(Assy. Only)	AD01032	1
33	Right Arm Link	AD01033	1
34	Clevis	AD01034	1
35	Set Screw	AD01035	1
36	Roll Pin	AD01036	1
37	Left Arm Link	AD01037	1
38	Roll Pin	AD01038	2
39	Left Jaw	AD01039	1
40	Slide	AD01040	1
41	Right Jaw	AD01041	1
42	Socket Head Cap Screw	AD01042	2
43	Socket Head Cap Screw	AD01043	2
44	Roll Pin	AD01044	2
45	Teeth (Straight)	AD01045	1
46	Stop Pin	AD01046	1
47	Trigger Guard Bracket	AD01047	1
48	Roll Pin	AD01048	3
49	Trigger	AD01049	1
50	Trigger Guard	AD01050	1
51	Pusher Assembly	AD03051	1
52	Lock Washer	AD01052	4
53	Socket Head Cap Screw	AD01053	4
54	Magazine Assembly	AD03054	1
59	Inlet Bushing	AD01059	1
89	Flexlock Nut	AD01089	1
200	Trigger Guard Bracket Assy.	AD01200	1