

GLF 443

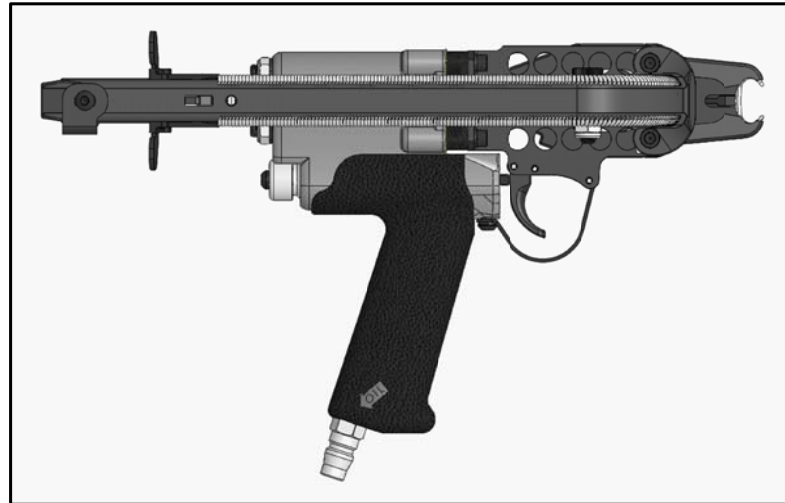

OPERATING INSTRUCTIONS & PARTS LIST

For best operating results and long life, maintain the tool in good working order, do not drop the tool, keep the mechanism free from dirt and other foreign matter and do not operate the tool at air pressures above 100 PSI (7.03 kg/cm²). Although your clip ring tool is of high quality and made to exacting standards, failure to follow proper operational precautions may result in damage to your tool and shorten its useful life.

OPERATION

The air powered clip ring tool should be held firmly in the hand and in most operations the tool is used 90 degrees to the work performed. It should be kept in mind that in using the air powered clip ring tool, this is like any other tool and should be properly maintained. One area of maintenance to be conscious of is when pushing the tool into foam, it should be cleaned occasionally. Also, when "grabbing" a group of wire, the tool is frequently used as a pusher puller and/or a variety of other things. The most important point to remember is to take a long, hard look at your work and choose the best way in which to do it. Obviously, the less the tool is abused, the better. The tool should be handled firmly in your hand and don't stretch too far when you use it in the direction of your application. Please also note that the tool should make a complete closure of the fastener. If for any reason you are not getting complete closure, check to make sure that the application is correct and that the tool is cycling completely. Obviously, moisture, dirt or any other foreign matter that is inside the tool will reduce its Operational efficiency. Please take care in handling, operation and maintenance of your tool for a long and useful work life.

AIR PRESSURE

Air pressure should be maintained at 85-96 PSI (5.98-6.68 kg/cm²) using 1/4" (6.35mm) ID air hose. Higher pressures will not increase the operating speed of the tool and may cause damage to it.

AIR FILTER AND REGULATOR

The air line should have an attached air line filter and regulator sufficient to provide a constant and even flow of clean, dry air. The filter should be installed as close as possible to the tool. Dirt or moisture in the air line will adversely affect the smooth operation of the tool and decrease its serviceable life.

LUBRICATION

To insure long, trouble-free service, we recommend Air Line Lubricators and Filter Units for proper lubrication and clean, dry air. A good grade of oil that emulsifies in water is recommended for air tools.

MANUAL OILING

Although the jaws and other moving parts of the tool do need to be oiled, periodic oiling in small amounts may increase the serviceable life of the tool that receives heavy use.

C-RINGS

These rings are available from ANN-CHAIN and will be shipped promptly from stock. PLEASE SEE C-RING STYLES CHART for further details regarding materials, points and size of C-RING.

REPAIR AND SERVICE PARTS

If any tool is not operating properly, remove it from service at once and have it checked for proper operation. ANN-CHAIN will ship replacement parts for repairs. Parts price lists are available upon request. Use only parts that are specifically fabricated for the AC model tool which you own.

TO DISASSEMBLE

Jaws, Magazine, Feeder Guide Rail

Remove Flexlock Nuts(21) and Jaw Bolts (#74). Take out Jaws(#40 and #50). Remove Magazine Assembly(#73) and Feeder Guide Rail (#204).

Feeder Blade, Rollers and Piston Rod

Remove Cap Screws (#18 & #39 x 4 pcs) and Frame Assy. (203) from Cylinder Housing. After taking off Piston(#30) and Piston Stop Spacer (#32). Piston Rod Assembly with Feeder Blade (#47) and Rollers (#46 x 4 pcs) can be taken out the front end of the Frame.

THROTTLE

Loosen Set Screws (#28) and remove Adjustable Valve Seats (#5 & #16). Using two Allen wrenches, unscrew Throttle Valve Screw (#9) to remove Valve units. One Valve will stay on Spacer (#14) and can be disassembled after removal from Housing.

TO ASSEMBLE

Assemble one Valve on Spacer (#14). Holding Allen wrench, bring second Valve mounted on Screw (#9) in from other side and complete Valve Assembly (should then have free motion of about 1/16").

THROTTLE VALVE ADJUSTMENT

With Throttle Spring Locator (#7 & #8) in place, partially screw in Adjustable Valve Seat (#5). With air partly turned on and holding front Valve closed with a 3/8" dia. turn Valve Seat in until air stops leaking through Valve. Using Throttle Stem (#17) to turn, install Front Valve Seat (#16), turning until air stops exhausting through Handle. After finer adjustment, lock Valve Seats in place with Set Screws (#28) in Housing casing.

TO LOCATE AND CORRECT AIR LEAKS

If an Adjustable Valve Seat is turned too far, the opposite Valve will be raised from its Bushing Seat, causing air leakage. To correct back off Adjustable Valve Seat until leak stops. If leaks do not stop, check Piston (#30) and Piston O-Ring (#29).

FEEDER BLADE, ROLLERS, PISTON ROD

Onto Piston Rod (#48) mount Feeder blade (#47), Roller Pins(#49 x 2pcs) and Rollers (#46 x 4 pcs). Put in Frame. Mount Piston Stop Spacer (#32), Piston (#30) and Flexloc Stop Nut (#21). Insert Throttle Stem (#17) and then assemble Frame to Housing.

FEEDER GUIDE RAIL

With Feeder Arm (#51) in place, assemble Feeder Guide Rail(#204). Pusher spring (#70), slide into Bracket and insert lower Cap Screw (#64) tight. Continue turning to desired Pusher Spring tension and lock with Nut (#67).

MAGAZINE

Assembly Latch(#45) and Latch Pin Clip (#43). Insert Jaw Bushings (#41 x 2 pcs) into Jaws (#40 & #50), side jaws into place and complete assembly.

ADJUSTMENT OF MAGAZINE

Before tightening Cap Screws (#74), insert enough Shims (#78) between Magazine(#73) and Side Plate(#35R) to produce a clearance between Magazine Shoe (#76) and Feeder Blade (47). Magazine must be held tight against Side Plate while checking this clearance; then, after tightening the Cap Screws (#74 x 2 pcs), clearance should be rechecked.

DO NOT POINT THE TOOL AT ANY PERSON. KEEP HANDS AND CLOTHING AWAY FROM THE FRONT OF JAWS OF THE TOOL AND AWAY FROM ALL MOVING PARTS. INJURY MAY RESULT. FAILURE TO FOLLOW THESE PRECAUTIONS MAY RESULT IN SERIOUS INJURY.

GLF 443

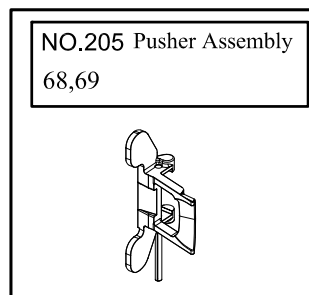
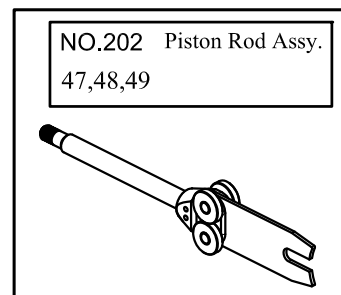
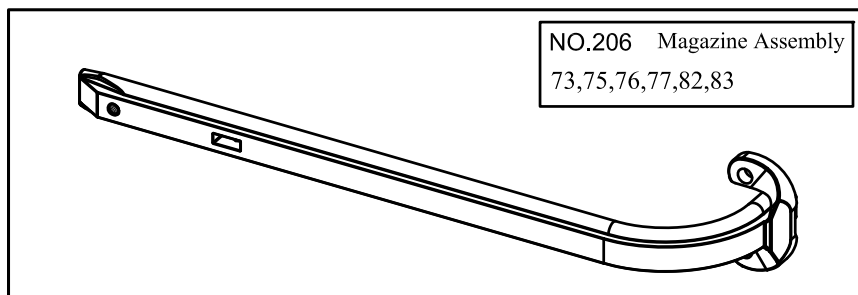
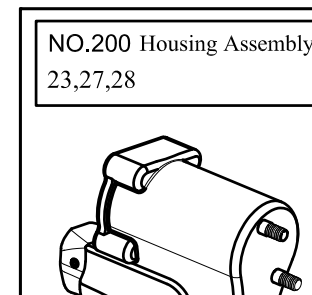
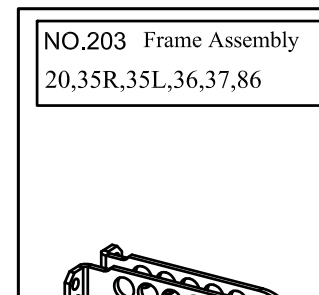
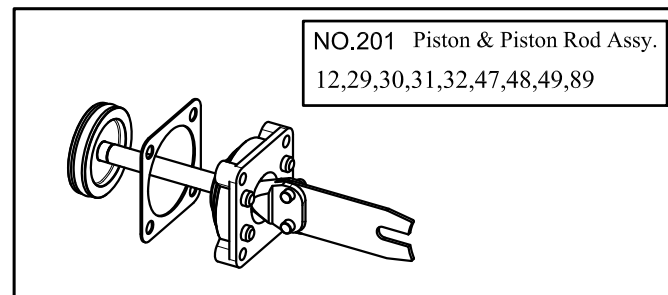
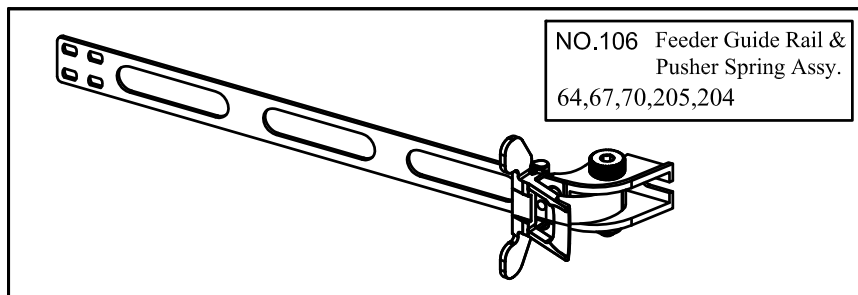
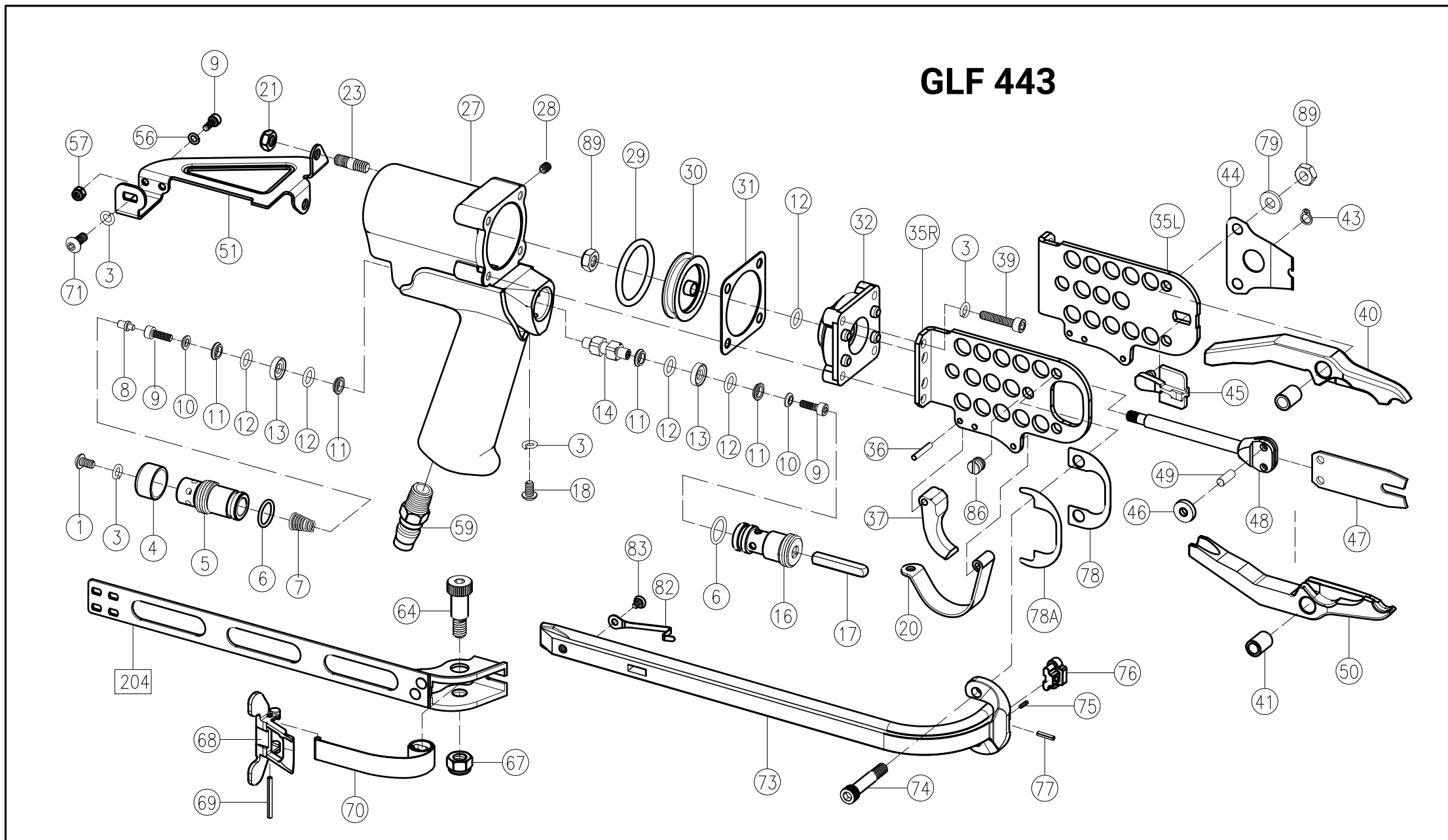

ITEM	DESCRIPTION	Model	PART NO.	Q'TY
1	Set Screw		01001	1
3	Shakeproof lock Washer		01003	7
4	Air Deflector		01004	1
5	Rear Valve Seat		01005	1
6	O-Ring		01006	2
7	Throttle Spring		01007	1
8	Throttle Spring Locator		01008	1
9	Throttle Valve Screw		01009	4
10	Valve Screw Washer		01010	2
11	O-Ring Support		01011	4
12	O-Ring		01012	5
13	O-Ring Center Support		01013	2
14	Throttle Valve Spacer		01014	1
16	Front Valve Seat		01016	1
17	Throttle Stem		01017	1
18	Button Head Cap Screw		01018	1
20	Trigger Guard		01020	1
21	Flexloc Nut		01021	2
23	Stud		601023	2
27	Housing		01027	1
28	Set Screw		01028	2
29	O-Ring		01029	1
30	Piston		01030	1
31	Cylinder Gasket		01031	1
32	Piston Stop Spacer	602	02032	1
		603	01032	
		604	01032	
		605	02032	
		35R	Side Plate (Right)	
35L	Side Plate (Left)		0135L	1
36	Roll Pin		01036	3
37	Trigger		01037	1
39	Socket Head Cap Screw		01039	4
40	Upper Jaw	602	02040	1
		603	03040	
		604	04040	
		605	05040	
		41	Jaw Bushing	
43	Latch Pin Clip		01043	1
44	Latch Spring	602	01044	1
		603	01044	
		604	01044	
		605	05044	
		45	Latch	
46	Roller	602	03045	4
		603	03045	
		604	03045	
		605	05045	
		602	02046	
47	Feeder Blade	602	01046	1
		603	03047	
		604	03047	
		605	05047	
		602	02048	
48	Piston Rod	602	03048	1
		603	03048	
		604	03048	
		605	03048	
		49	Roller Pin	
50	Lower Jaw	602	02050	1
		603	03050	
		604	04050	
		605	05050	
		51	Feeder Arm	
56	Washer		01005	2
57	Nut		01006	2
59	Inlet Bushing		01059	1
64	Socket Head Cap Screw		01064	1
67	Nut		01067	1
68	Pusher		602068	1
69	Extruded Rivet		01069	1
70	Pusher Spring		01070	1
71	Button Head Screw		01018	1
73	Magazine Body		02M073	1
74	Jaw Bolt		02074	2
75	Magazine Spring		02075	2
76	Magazine Shoe		02M076	1
77	Roll Pin		02077	1
78	Magazine Shim		01078	1
78A	Magazine Shim		0178A	1
79	Washer		01079	2
86	Plate Screw		01086	1
89	Flexloc Nut		01089	3
106	Feeder Guide Rail & Pusher Spring Assy.		602106	1
200	Housing Assy.		601200	1
201	Piston & Piston Rod Assy.	602	02201	1
		603	03201	
		604	03201	
		605	05201	
		602	02202	
202	Piston Rod Assy.	602	03202	1
		603	03202	
		604	03202	
		605	05202	
		203	Frame Assy.	
204	Feeder Guide Rail Assy.		602204	1
205	Pusher Assy.		602205	1
206	Magazine Assy.		02M206	1