

# GLF 9/16 UTO

## OPERATING INSTRUCTIONS

STEP 1. Push back pusher to end position of magazine

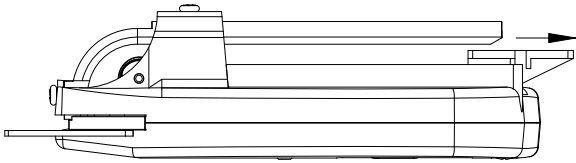

STEP 2. Load D-Rings on the magazine.

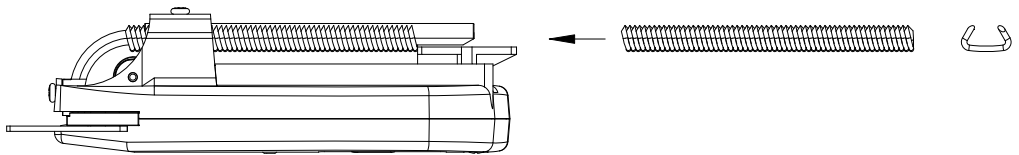

STEP 3. Push pusher forward to the end of D-Ring.

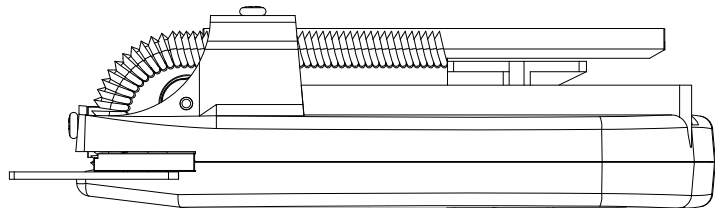

This tool is compliant with or conforms to EN 792-13



GREAT LAKES FASTENING  
2810 HOITT AVENUE, KNOXVILLE, TN 37917  
TEL: 877.969.0031 FAX: 877-969-0032

[WWW.GLFAST.COM](http://WWW.GLFAST.COM)



# GLF 9/16 UTO

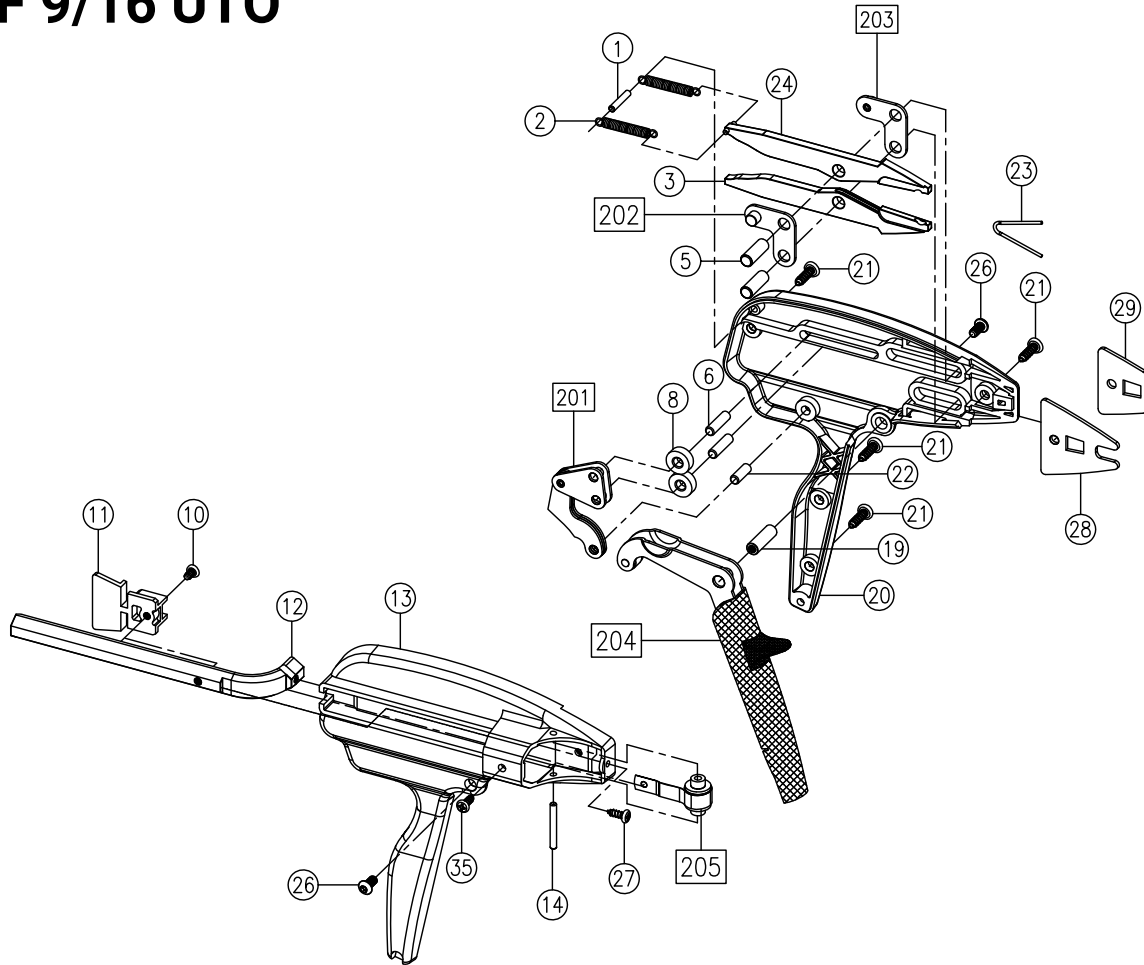

## PARTSLIST

ITEM	DESCRIPTION	PART NUMBER	Q'TY	ITEM	DESCRIPTION	PART NUMBER	Q'TY
1	Pin	14001	1	21	Screw	14021	4
2	Spring	14002	2	22	Pin	14022	1
3	Lower Jaw	14003	1	23	V Spring	14023	1
5	Pin	14005	2	24	Upper Jaw	14024	1
6	Pin	14006	2	26	Screw	14026	2
8	Roller	14008	2	27	Screw	14027	1
10	Screw	14010	1	28	Guide	14028	1
11	Pusher	14011	1	29	Guide (Optional)	14S029	1
12	Magazine	14012	1	35	Screw	14035	1
13	Housing (Right)	14013	1	201	Delta Lamination Assy.	14201	1
14	Pin	14014	1	202	Jaw Link Assy. (Right)	14202	1
15	Pusher Spring	14015	1	203	Jaw Link Assy. (Left)	14203	1
16	Plastic Roller	14016	1	204	Handle Assy.	14204	1
19	Pin	14019	1	205	Spring Assy.	14205	1
20	Housing (Left)	14020	1				

## RECOMMENDED SPARE PARTS LIST

ITEM	DESCRIPTION	PART NUMBER	QTY
2	Spring	14002	2
11	Pusher	14011	1
12	Magazine	14012	1
23	V Spring	14023	1
205	Spring Assembly	14205	1

### THE WAYS OF ELIMINATING SIMPLE BREAKDOWN

#### ◆ Jamming problems

The most common reason is insufficient pusher spring tension. This occurs when the tool is forced to function when ring quantity is not sufficient. This tool is not designed to empty its magazine during operation. Reload when the pusher makes contact with the tunnel in the housing.

If a jam occurs, pull pusher back to the locked position and pull rings out of jaw mechanism area. Point nose of tool down while holding onto rings, cycle tool slowly. User may need to shake pliers to assist the ring in falling out. This should force jammed ring out of jaw mechanism.

#### ◆ Ring does not close completely

1. Check for foreign debris in the jaw area. This is especially true in the area between the housing and rollers.
2. The jaws may be worn from extended use, replacing the jaw(s) is recommended.
3. When the tool is used in corrosive applications, a water dispersing lubricating oil should be applied on a regular basis to the jaw pins and rollers. Unlubricated and/or corroded jaw pins may cause the tool to function poorly.

#### ◆ Feeding problems

1. If rings do not feed smoothly down the magazine, check pusher spring for tension. If the magazine is covered with dirt from field use, clean the magazine and apply a light coating of water dispersing lubricating oil. If magazine is worn or damaged, replace it.
2. When rings feed properly on the magazine but do not feed into the jaws without spitting out of the magazine side of the tool, or if the rings sit in the jaw grooves on an angle, check jaws to insure freedom of movement.
3. If jaws do not open completely allowing the next ring to enter jaws, check the jaw open spring for wear or need of replacement.
4. Never use loose rings in the D-Ring hand Pliers B14.

## SPECIFICATIONS FOR D-RING

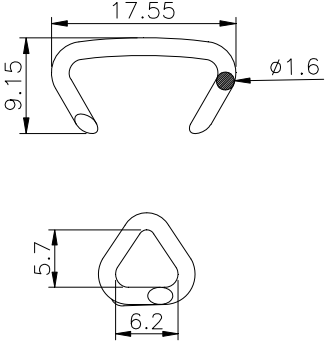
Wire Diameter	1.6mm	
Closure Size	5.7x6.2mm	
Ring Box Quantity	2500 pcs	
Ring Stick Quantity	50 pcs	
Material	Galvanized / Stainless Steel Aluminum / Zinc-Aluminum	

## PERIODIC MAINTENANCE

### 1. Keeping clean of the tools

Do not set tools at the place where will get damage easily. Please keep from dust and humidification. Putting the tool in proper temperature is very important when the tool does not be used for a long time.

### 2. Cleaning the obstacle inside of tool

After using tools, please clean any obstacle blocking in JAWS (#40, #50). Keeping the tools clean is better.

### 3. Putting down tools lightly

After work, please put tools down lightly to avoid damaging the body and the magazine of tool.

## LIMITED WARRANTY

Great Lakes Fastening warrants that the D-Ring Hand Pliers is free from defects in material and workmanship under normal use, within half year from the date of purchase, in the country of purchase. The warranty is extended to the original purchaser only. All parts except the consumable parts are The warranty is extended to the original purchaser only. All parts except the consumable parts are warranted for half year from date of purchase and will be replaced if the sole judgment of Great Lakes Fastening they should be deemed defective over and above that considered to be normal wear.

## WARNING

- ◆ Always read tool manual before operating.
- ◆ Do not point the tool at anyone.
- ◆ Keep hands and clothing away from the front of Jaws of the tool and away from all moving parts. Injury may result. Failure to follow these precautions may result in serious injury.
- ◆ Keep others at a safe distance from the tool while the tool is in operation as actuation occurs, possibly causing injury.
- ◆ Always wear safety glasses while operating or while in the vicinity of a tool in operation.
- ◆ Always operate tool in an unobstructed work area.